

winterhalter

Spare Parts List

GM 85 (GM 170)

Revised 05/98

Part no. 89000602

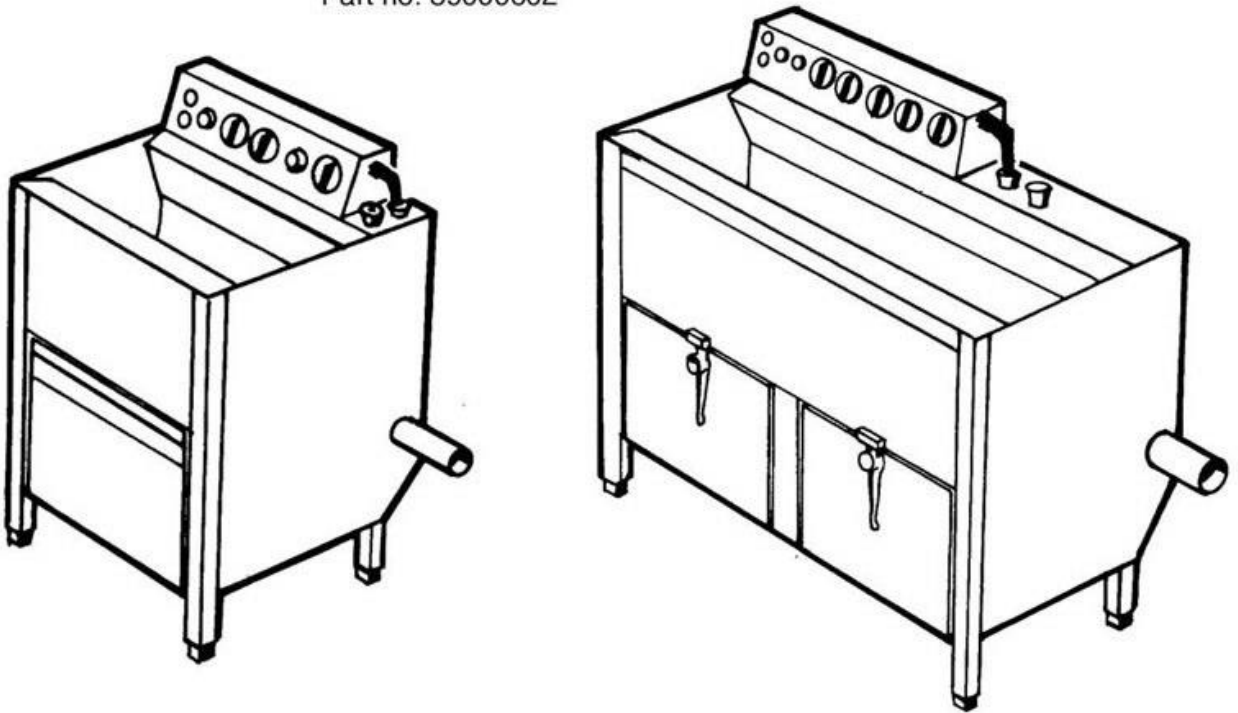

Summary

Water supply and shower

Page 1 and 2

Wash system

Page 3 and 4

Drain and overflow

Page 5 and 6

Base frame and centrifuge

Page 7 and 8

Electrical parts

Page 9 and 10

GM 85 (GM 170)

Wasserzulauf und Brause Water inlet and shower Alimentation d'eau et arrosoir

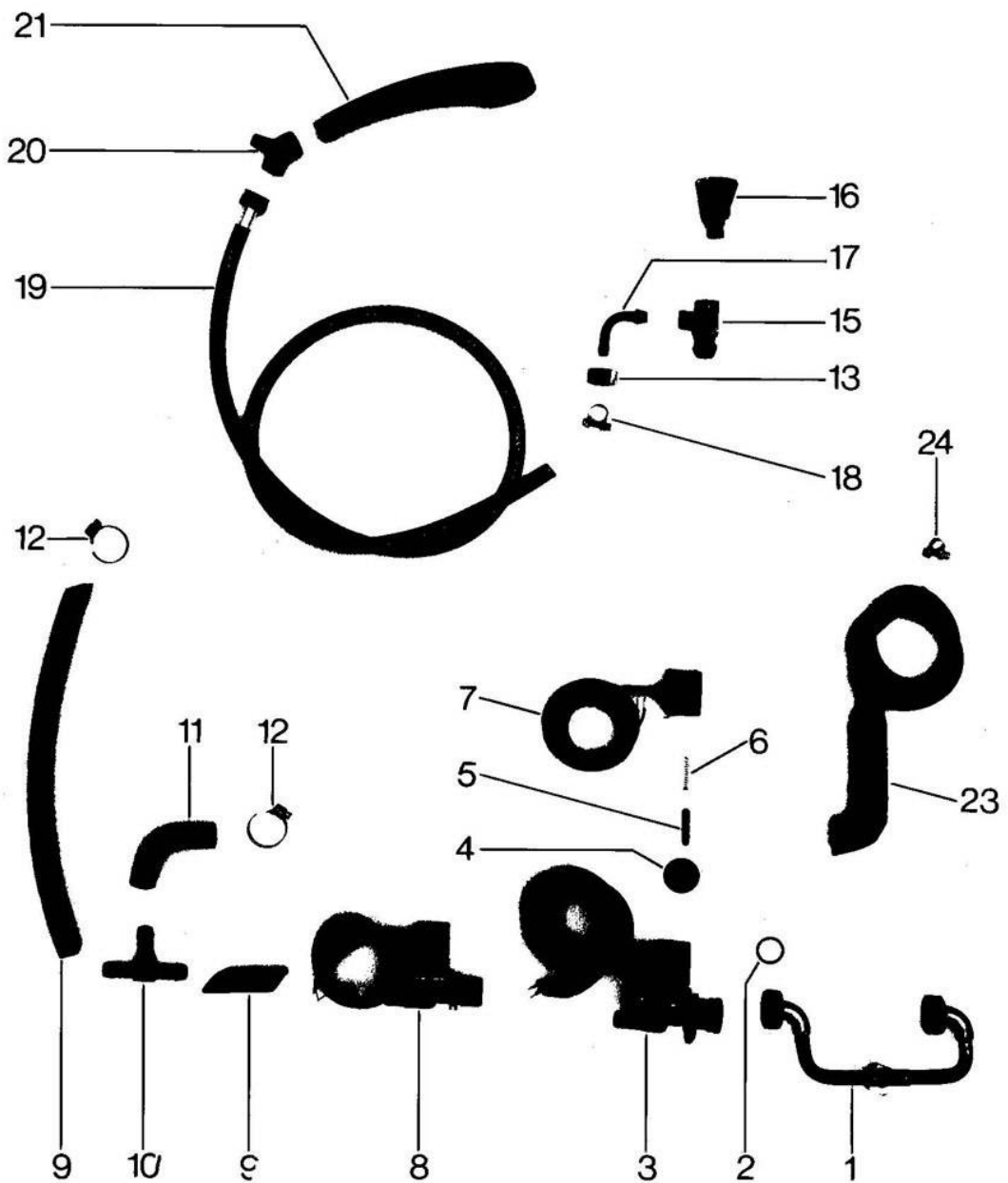

GM 85 (GM 170) - Water supply and shower

Pos.	Designation	Part no.	Notes
1	Inlet pipe	55 11 005	
2	Seal 19,5 x 24	27 09 010 ★	
3	Solenoid valve	31 06 187	1 x GM 85, 2 x GM 170
4	Diaphragm	31 06 047 ★	no more available
5	Plunger	31 06 073 ★	
6	Spring	31 06 049	
7	Coil	31 06 052	
9	Hose 13 x 3,5	40 02 002 ★	per metre
10	T-hose connection	29 06 001 ★	
11	Hose elbow ø 14	40 03 001 ★	
12	Hose clip 14 x 22	28 02 301 ★	
13	Coupling nut 3/8"	29 07 200 ★	
n.p.	Cutting ring ø 10	29 07 303 ★	
n.p.	Copper pipe 10 x 1	05 20 001 ★	per metre
15	Tap bottom part	29 03 211	
16	Tap top part	29 03 212	
17	Hose elbow	29 06 500 ★	
18	Hose clip ø 13	28 02 006 ★	
19	Shower hose	29 01 239	
20	Slip-on angle	29 01 240	
21	Shower head	29 01 507	
n.p.	Hose clip 20-30	28 02 306 ★	
23	Air chamber	40 07 024 ★	
24	Hose clip ø 9	28 02 102 ★	
n.p.	Inlet jets	28 14 212	only GM 170
n.p.	Cover (sol valve)	35 01 515	
n.p.	Sheet-metal nut	21 17 300	
n.p.	Cylinder screw	20 20 300	
n.p.	Double solenoid valve	31 06 063	GM 170
n.p.	Coil	31 06 110	

GM 85 (GM 170)
Wasserzulauf und Brause
Water inlet and shower
Alimentation d'eau et arrosoir

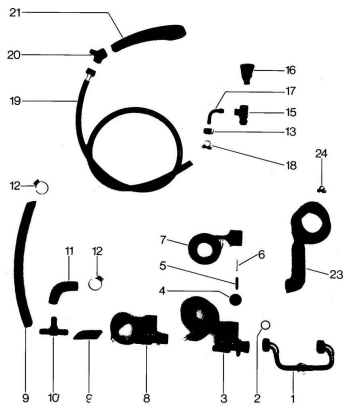

GM 85 (GM 170)

**Waschsystem
Wash system
Système de lavage**

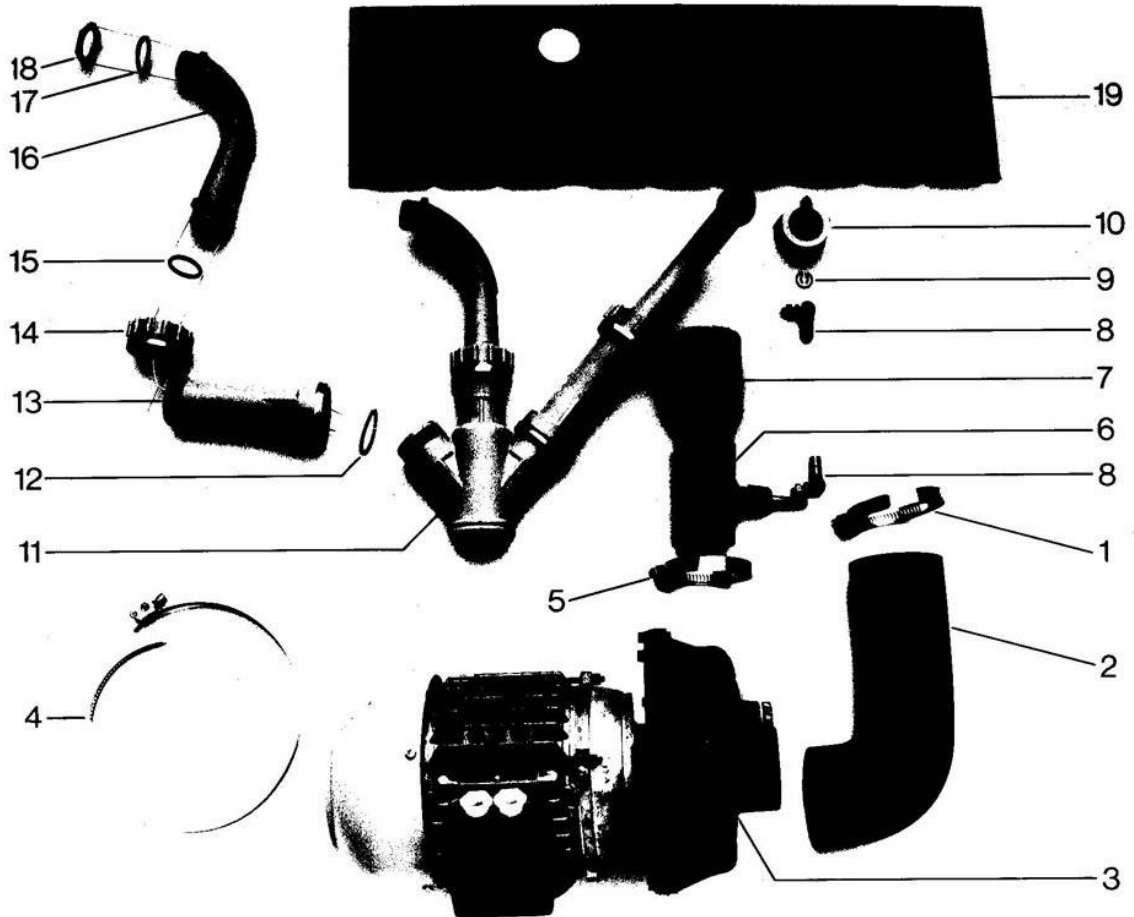

GM 85 (GM 170) - Wash system

Pos.	Designation	Part no.	Notes
1	Hose clip 62-82	28 02 120 ★	
2	Hose elbow	40 03 028 ★	
3	Pump 1,7 kW 230/400V / 50 Hz	31 02 263 ★	GM 85 + 170
	Pump 1,7 kW 230/400V / 60 Hz	31 02 267	
	Pump 1,7 kW 230 V	31 02 265	
n.p.	Capacitors	31 13 001 ★	
n.p.	Counter ring	27 10 014 ★	
n.p.	Motor shaft seal	27 10 013 ★	
n.p.	Impeller	31 02 206 ★	
n.p.	Pump housing	31 02 204 ★	
n.p.	O-ring	31 02 209	
4	Hose clip 152-172	28 02 123 ★	
5	Hose clip 47-67	28 02 115 ★	
6	Throttle valve	55 27 096	since 6/82
7	Pump hose \varnothing 50 x 4,5 x 90	55 05 018 ★	
8	Hinge head	28 15 020	
9	Annular spring	23 12 300 ★	
10	Control knob with axle	55 19 051	since 10/86
11	Manifold top part	55 06 005	only manifold part
12	Seal 39 x 32	27 02 001 ★	
13	Extension	35 01 003 ★	
14	Coupling nut	35 01 004 ★	
15	O-ring 24 x 3	27 07 026 ★	
16	Angle	35 01 005 ★	
17	Seal 33 x 26	27 01 003 ★	
18	Locking nut 3/4" BSP	61002626	
19	Wash jet	35 01 506	
n.p.	Coarse sieve 20-85.203	55 13 016	
n.p.	Fine sieve 20-85.205	55 13 017	
n.p.	Inset rack	55 01 110	
n.p.	Bifurcated piece (manif.) polypr.	35 01 173	only GM 170
n.p.	Welding arc polyproylene	35 01 174	
n.p.	Coarse sieve with lap joint	55 13 016	only GM 170 right

GM 85 (GM 170)

Ablauf und Überlauf Drain and overflow Ecoulement et surverse

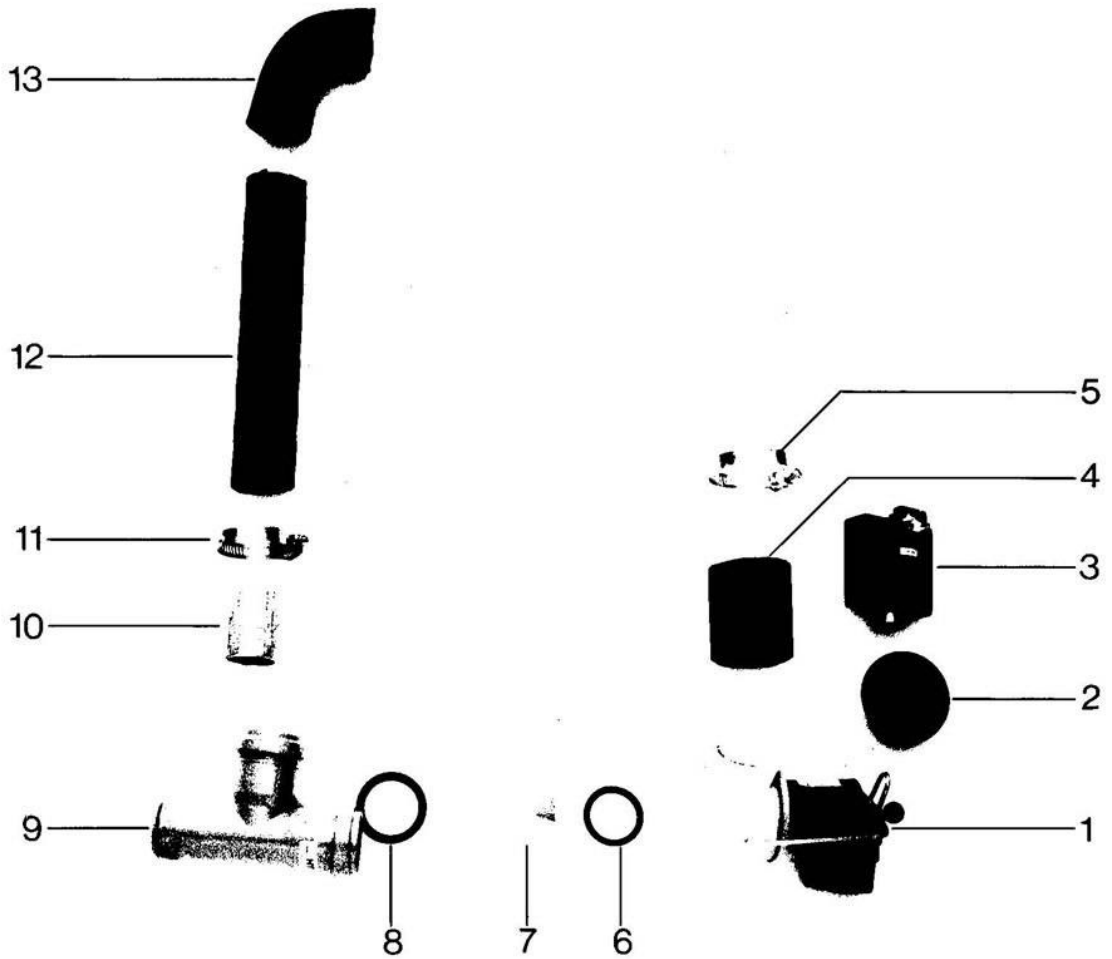

GM 85 (GM 170)

Untergestell und Schleuder Base frame and centrifuge Châssis et essoreuse

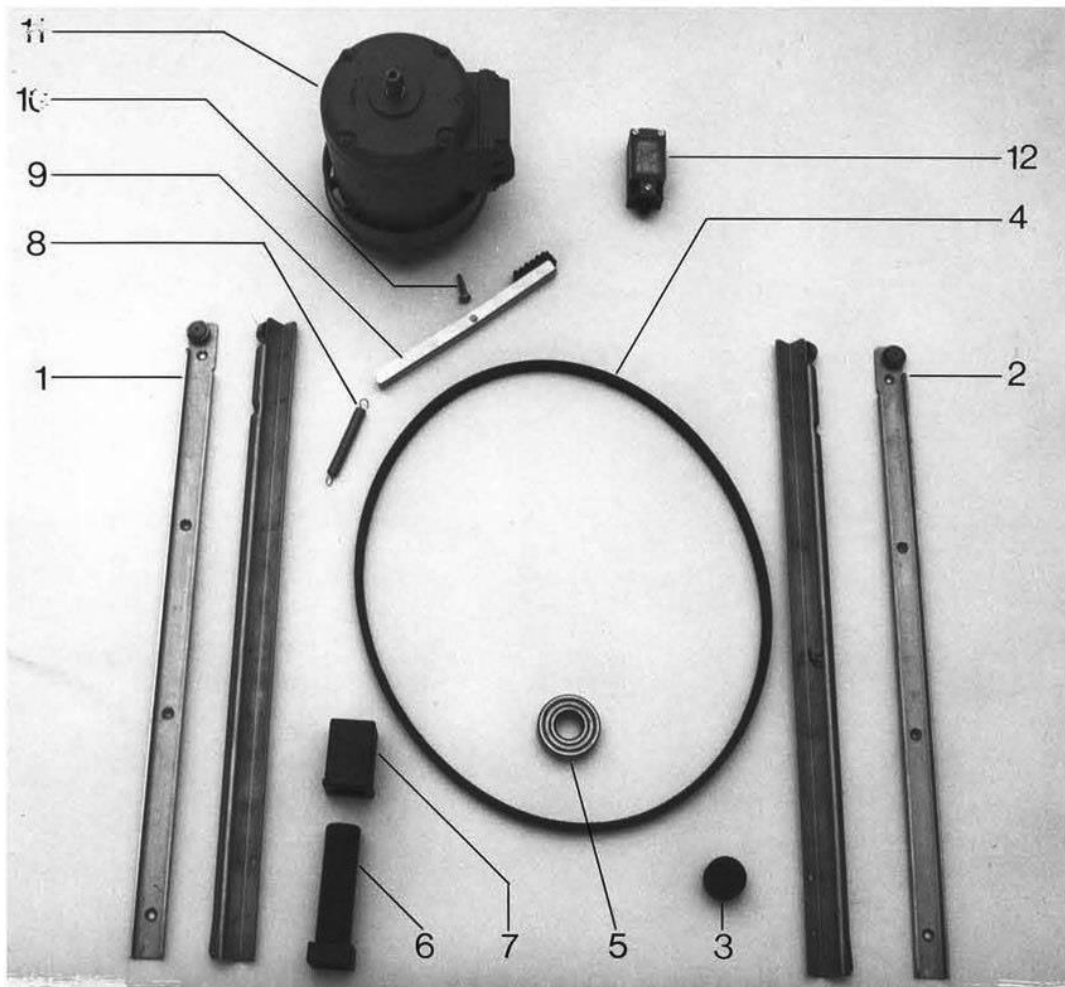

GM 85 (GM 170) - Base frame and centrifuge

Pos.	Designation	Part no.	Notes
n.p.	Catch bowl	55 27 011	
n.p.	Machine cover	55 27 012	only GM 85
1	Guide profile left	28 01 033	
2	Guide profile right	28 01 047	
n.p.	Centrifuge insert	55 01 096	Rilsan
n.p.	Centrifuge basket	85000486	CNS
3	Rubber buffer	40 06 001	
4	V-belt 10 x 1060	40 08 009	
5	Grooved ball bearing	28 01 003	
6	Foot	35 01 064	★
7	Insert	35 01 062	★
10	Cylinder screw	20 19 300	★
11	Centrifuge motor 220/380 V	31 01 027	
n.p.	Motor bracket	55 14 099	
n.p.	Catch bowl	55 27 011	
n.p.	Capacitor	31 13 034	
12	Limit switch	31 24 104	until 5/91
n.p.	Centrifuge cover	35 01 522	
n.p.	Ball bearing inox	28 01 046	for pos. 1 or 2
n.p.	Buffer	40 06 001	
n.p.	Forelock	28 05 041	
n.p.	Door handle with bolt	28 05 042	
n.p.	Bearing cpl.	55 27 100	
n.p.	V-belt pulley (motor)	28 10 016	D 70 x 26
n.p.	V-belt pulley (motor 60 Hz)	67000433 4	D 57 x 26
n.p.	Cover for motor	35 01 526	
n.p.	Rectifier (motor)	31 13 053	
n.p.	Centrifuge cylinder	55 02 004	w. pulley + bearing bush
n.p.	Shaft seal	27 08 002	
n.p.	Rubber stop buffer	40 06 015	

GM 85 (GM 170)

Elektrobestückung
Electrical parts
Matériel électrique

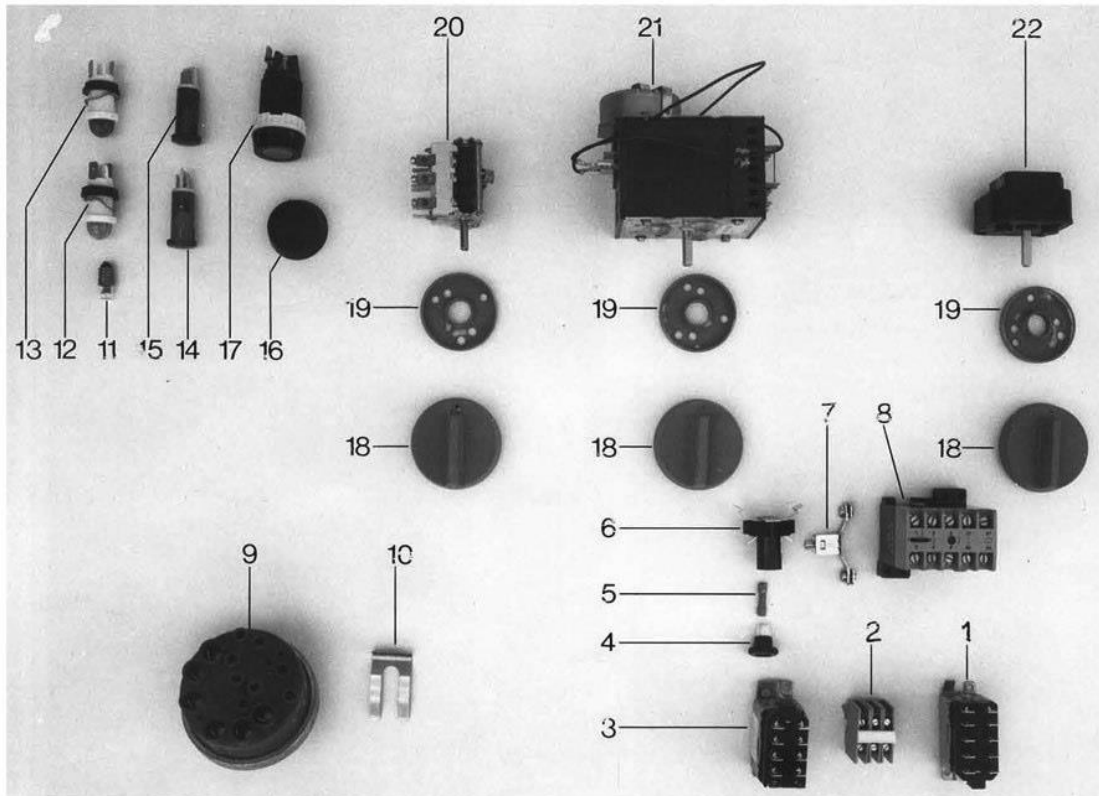

GM 85 - Electrical parts

Pos.	Designation	Part no.	Notes
1	Mini-contactor	31 04 034 ★	3 S 1 Ö pump
2	Series terminal 3-pole	31 09 010 ★	
3	Mini-contactor	31 04 035 ★	2 S 1 Ö control
4	Screwing cap	31 11 048 ★	
5	Fuse insert	31 11 043 ★	
6	Fuse base	31 11 057 ★	
7	Earth terminal	31 09 013 ★	
8	Mini-contactor	31 04 022 ★	motor
9	Level switch	55 28 236	
10	Friction spring	31 26 001 ★	
11	Low volt neon-glow lamp	31 08 006 ★	
12	Pilot light round	31 08 026	yellow - old
13	Pilot light round	31 08 001 ★	red - old
14	Pilot light	31 08 002 ★	green
15	Pilot light	31 08 026 ★	white
16	Seal cap transparent	31 24 006 ★	
17	Pressure switch	31 24 002 ★	1 x for water drain 1 x for manual washing until masch. no.: 365 184
18	Control knob	55 19 036 ★	
19	Labyrinth seal ø 47	35 01 092	
20	Circuit closer	55 28 138 ★	
n.p.	Circuit closer	31 24 180	as from 8/92
21	Programme switch	30000214	15 min.
22	Timer	31 05 111	centrifuge, until masch. no.: 365 184
n.p.	Control box plate	28 03 133	
n.p.	Control box plate	28 03 134	
n.p.	Safety switch (limit switch) for centrifuge	31 24 174	as from series 2615 (28/05/91)
n.p.	Synchronous motor 220/240 V 60 H	31 05 124	
n.p.	Sheet-metal nut B 3,5	21 17 002	for fixing rear panel
n.p.	Sheet-metal screw 3,9 x 13	20 21 302	
n.p.	Wipe cont. flick cont.	31 04 150	for water drain as from mach. no.: 365 184
n.p.	Pressure switch	67000553	green; control
n.p.	Pressure switch	67000554	yellow; water drain
n.p.	Pressure switch	67000555	yellow; manual washing
n.p.	Pressure switch	67000556	yellow; centrifuge